



## SPECIFICATION

宏致電子股份有限公司

桃園縣中壢市東園路13號

No.13, Dongyuan Rd., Jhongli City,

Taoyuan County 320, Taiwan (R.O.C.)

TEL: +886-3-463-2808

FAX: +886-3-463-1800

SPEC. NO.: PS-51765-XXXXX-XXX

REVISION: A

PRODUCT NAME: PCI Express M.2 CONNECTOR

PRODUCT NO: 51765 SERIES

PREPARED:  <b>LiuHua</b>  DATE: <b>2019/03/22</b>	CHECKED:  <b>Brave</b>  DATE: <b>2019/03/22</b>	APPROVED:  <b>XuZhiYong</b>  DATE: <b>2019/03/22</b>
------------------------------------------------------------------	----------------------------------------------------------------	---------------------------------------------------------------------



TITLE: **PCI EXPRESS M.2 CONNECTOR**

RELEASE DATE: 2019/03/22

REVISION: A

ECN No: ECN-1903263

PAGE: **2** OF **12**

1	REVISION HISTORY .....	3
2	SCOPE .....	4
3	APPLICABLE DOCUMENTS .....	4
4	REQUIREMENTS .....	4
5	PERFORMANCE .....	5
6	INFRARED REFLOW CONDITION.....	8
7	PRODUCT QUALIFICATION AND TEST SEQUENCE .....	9
8	MODULE CARD OPERATION.....	10
9	RECOMMEND MODULE CARD .....	11



Aces P/N: **51765 series**

TITLE: **PCI EXPRESS M.2 CONNECTOR**

RELEASE DATE: 2019/03/22

REVISION: A

ECN No: ECN-1903263

PAGE: 3 OF 12

### 1 Revision History

Rev.	ECN #	Revision Description	Prepared	Date
A	ECN-1903263	NEW PRODUCT RELEASE	LiuHua	

TITLE: **PCI EXPRESS M.2 CONNECTOR**

RELEASE DATE: 2019/03/22

REVISION: A

ECN No: ECN-1903263

PAGE: 4 OF 12

## 2 SCOPE

This specification covers performance, tests and quality requirements for **PCI Express M.2 Connector**

## 3 APPLICABLE DOCUMENTS

EIA-364: ELECTRONICS INDUSTRIES ASSOCIATION

## 4 REQUIREMENTS

### 4.1 Design and Construction

- 4.1.1 Product shall be of design, construction and physical dimensions specified on applicable product drawing.
- 4.1.2 All materials conform to R.o.H.S. and the standard depends on TQ-WI-140101.

### 4.2 Materials and Finish

- 4.2.1 Contact: High performance copper alloy (**Phosphor Bronze**)
  - Finish: (a) Contact Area: **Refer to the drawing.**
  - (b) Under plate: **Refer to the drawing.**
  - (c) Solder area: **Refer to the drawing.**
- 4.2.2 Housing: Thermoplastic or Thermoplastic High Temp., UL94V-0
- 4.2.3 Hold Down: High performance copper alloy(**Phosphor Bronze**)
  - Finish: (a) Under plate: **Refer to the drawing.**
  - (b) Solder area: **Refer to the drawing.**

### 4.3 Ratings

- 4.3.1 Working Voltage Less than **36 Volts AC (per pin)**
- 4.3.2 Voltage: **50 Volts AC (per pin)**
- 4.3.3 Current: **0.5 Amperes (per pin)**
- 4.3.4 Operating Temperature : **-40°C to +80°C**

TITLE: **PCI EXPRESS M.2 CONNECTOR**

RELEASE DATE: 2019/03/22

REVISION: A

ECN No: ECN-1903263

PAGE: **5** OF **12**

## 5 Performance

### 5.1. Test Requirements and Procedures Summary

Item	Requirement	Standard
Examination of Product	Product shall meet requirements of applicable product drawing and specification.	Visual, dimensional and functional per applicable quality inspection plan.
<b>ELECTRICAL</b>		
Item	Requirement	Standard
Low Level Contact Resistance	Initial: <b>55 mΩ</b> Max. per contact After test: <b>20 mΩ</b> Max. change allowed	Mate connectors, measure by dry circuit, <b>20mV</b> Max., <b>100mA</b> Max. (EIA-364-23)
Insulation Resistance	<b>500 MΩ</b> Min.	Unmated connectors, apply <b>500 V</b> DC between adjacent terminals. (EIA-364-21)
Dielectric Withstanding Voltage	No discharge, flashover or breakdown. Current leakage: <b>1 mA</b> max.	<b>300 V AC</b> Min. at sea level for <b>1</b> minute. Test between adjacent contacts of unmated connectors. (EIA-364-20)
Temperature Rise	<b>30°C</b> Max. Change allowed	Mate connectors: measure the temperature rise at rated current until temperature stable. The ambient condition is still air at 25°C (EIA-364-70, Method2)

TITLE: **PCI EXPRESS M.2 CONNECTOR**

RELEASE DATE: 2019/03/22

REVISION: A

ECN No: ECN-1903263

PAGE: **6** OF **12**

<b>MECHANICAL</b>		
<b>Item</b>	<b>Requirement</b>	<b>Standard</b>
Durability	25 Cycles	The sample should be mounted in the tester and fully mated and unmated the number of cycles. (EIA-364-09)
Durability (precondition)	Perform 5 mate/unmate cycles if the application requires up to 25 over the life of the connector. 20 cycles if the application requires 26~200; or, 50 cycles if the application requires 201 or greater.	No evidence of physical damage (EIA-364-09)
Mating Forces	Mating Force: 25 N Max.	Measure the force required to mate/unmate connector. (EIA-364-13 Method A) °
Vibration	1 microsecond Max.	15 minutes in each of 3 mutually perpendicular directions. Both mating halves should be rigidly fixed so as not to contribute to the relative motion of one contact against another. The method of fixturing should be detailed in the test report. (EIA-364-28 Condition VII Condition letter D)
Shock (Mechanical)	1 microsecond Max.	Mate connectors to 250G (Ultra-book) and 285 G (Tablet) at 2 milliseconds half sine on all six axis.
Reseating	Appearance: No damage	Manually mated/unmated the connector or socket perform 3 cycles.

TITLE: **PCI EXPRESS M.2 CONNECTOR**

RELEASE DATE: 2019/03/22

REVISION: A

ECN No: ECN-1903263

PAGE: 7 OF 12

**ENVIRONMENTAL**

Item	Requirement	Standard
Resistance to <b>Reflow</b> Soldering Heat	See Product Qualification and Test Sequence Group <b>11 (Lead Free)</b>	Pre Heat : <b>150°C~180°C</b> , 60~120sec. Heat : <b>230°C</b> Min., 40sec Min. Peak Temp. : <b>260°C</b> Max, 10sec Max.
Thermal Shock	See Product Qualification and Test Sequence Group <b>2</b>	Mate module and subject to follow condition for <b>10</b> cycles. 1 cycles: <b>-55 +0/-3 °C, 30 minutes.</b> <b>+85 +3/-0 °C, 30 minutes.</b>
Cyclic Temperature & Humidity	See Product Qualification and Test Sequence Group <b>2</b>	Cycle the connector or socket between <b>25°C±3°C</b> at <b>80±3% RH</b> and <b>65°C±3°C</b> at <b>50%±3% RH</b> . Ramp times should be 0.5hrs. and dwell times should be 1.0 hrs. Dwell times start when the temperature and humidity have stabilized within the specified levels. Perform 24 such cycles. (EIA-364-31, Method III)
Temperature Life	See Product Qualification and Test Sequence Group <b>1</b>	Subject mated connectors to temperature life at <b>105°C</b> for <b>120 hours</b> . (EIA-364-17, method A)
Temperature Life (precondition)	No physical damage	Subject mated connectors to temperature life at <b>105°C</b> for <b>72 hours</b> . (EIA-364-17, method A)
Salt Spray (Only For Gold Plating)	See Product Qualification and Test Sequence Group <b>8</b>	Subject mated connectors to 5% salt-solution concentration, 35°C <b>(I) Gold flash for 8 hours</b> <b>(II) Gold plating 15 u" for 96 hours.</b> (EIA-364-26)
Solder Ability	Tin plating: Solder able area shall have minimum of <b>95%</b> solder coverage. Gold plating: Solder able area shall have minimum of <b>75%</b> solder coverage	Add then into solder bath, Temperature at <b>245 ±5°C</b> , for <b>4-5</b> sec. (EIA-364-52)
Hand Soldering Temperature Resistance	Appearance: No damage	T ≥ <b>350°C</b> , 3sec at least.

ENVIRONMENTAL		
Item	Requirement	Standard
Thermal Disturbance	See Product Qualification and Test Sequence Group 10	Cycle the mated connector between $15^{\circ}\text{C}\pm 3^{\circ}\text{C}$ and $85^{\circ}\text{C}\pm 3^{\circ}\text{C}$ , as measured on the part. Ramps should be a minimum of $2^{\circ}\text{C}$ per minute, and dwell times should insure that the contacts reach the temperature extremes (a minimum of 5 minutes). Humidity is not controlled. Perform 10 such cycles.

**Note.** Flowing Mixed Gas shall be conduct by customer request.

## 6 INFRARED REFLOW CONDITION

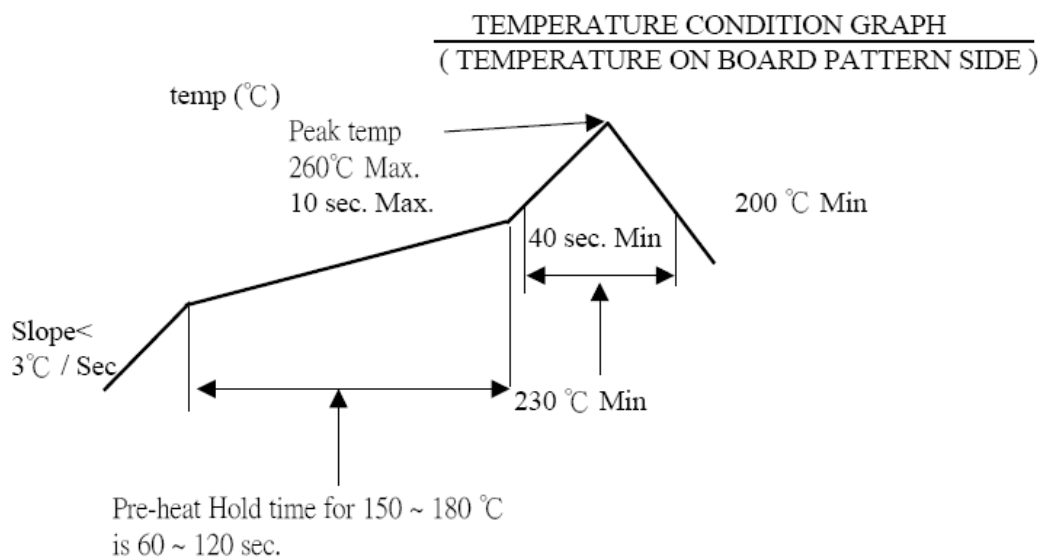





**7 PRODUCT QUALIFICATION AND TEST SEQUENCE**

Test or Examination	Test Group										
	1	2	3	4	5	6	7	8	9	10	11
	Test Sequence										
Examination of Product	1-6 9	1-6 9-12	1-6 9	1-7	1-4	1-3	1-7	1-5	1-3	1-5	1-3
Low Level Contact Resistance	2-5 8	2-5 8-11	2-5 8	2-6			2-4 6	2-4		2-4	
Insulation Resistance					2						
Dielectric Withstanding Voltage					3						
Mating / Unmating Forces				3-5							
Durability				4							
Durability(precondition)	3	3	3				3				
Temperature Rise						2					
Vibration			7								
Shock (Mechanical)							5				
Reseating	7	10									
Thermal Shock		4									
Cyclic Temperature & Humidity		7									
Temperature Life	4										
Temperature Life(precondition)			4								
Salt Spray								3			
Solder Ability									2		
Thermal Disturbance										3	
Resistance to Soldering Heat											2
Sample Size	4	4	4	4	4	4	4	4	4	4	4

## 8 MODULE CARD OPERATION

Exercise care when handling connectors. Follow recommendations given below.

8-1 Angled insertion is allowable.

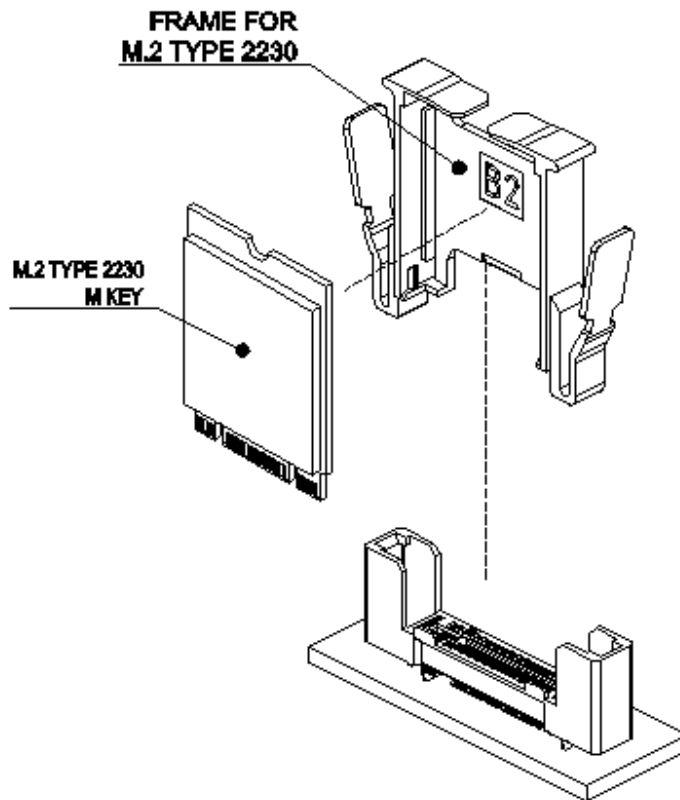

8-2 Prohibition with angles mate/unmates the module card.

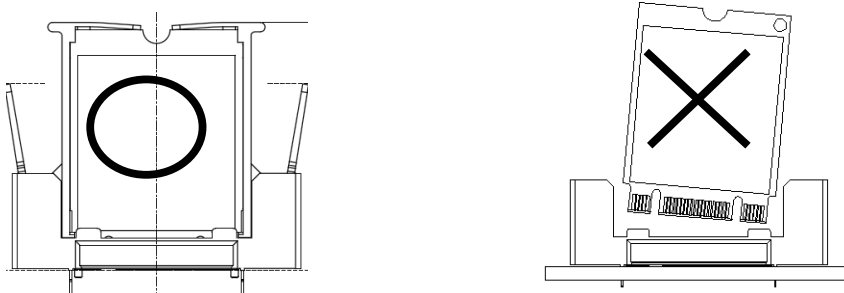

### 9 RECOMMEND MODULE CARD

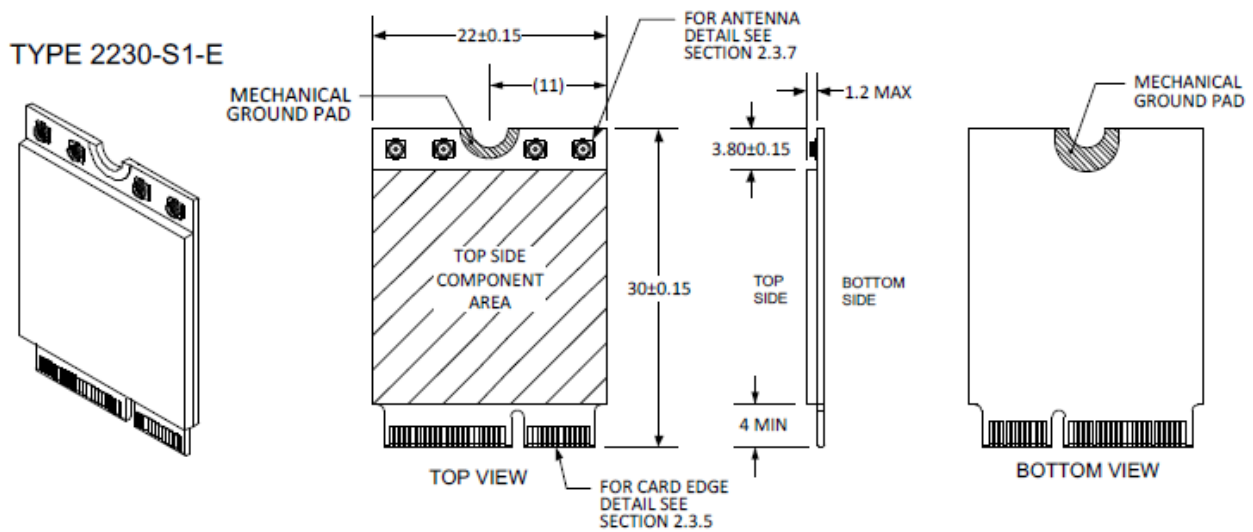
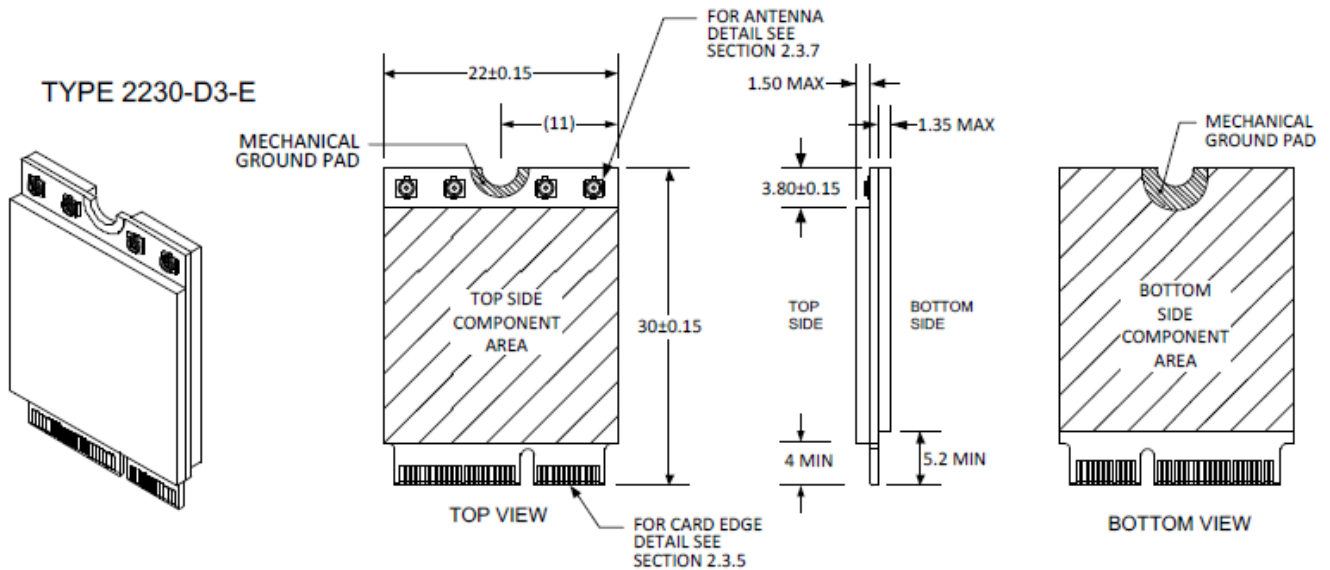

TITLE: **PCI EXPRESS M.2 CONNECTOR**

RELEASE DATE: 2019/03/22

REVISION: A

ECN No: ECN-1903263

PAGE: 12 OF 12

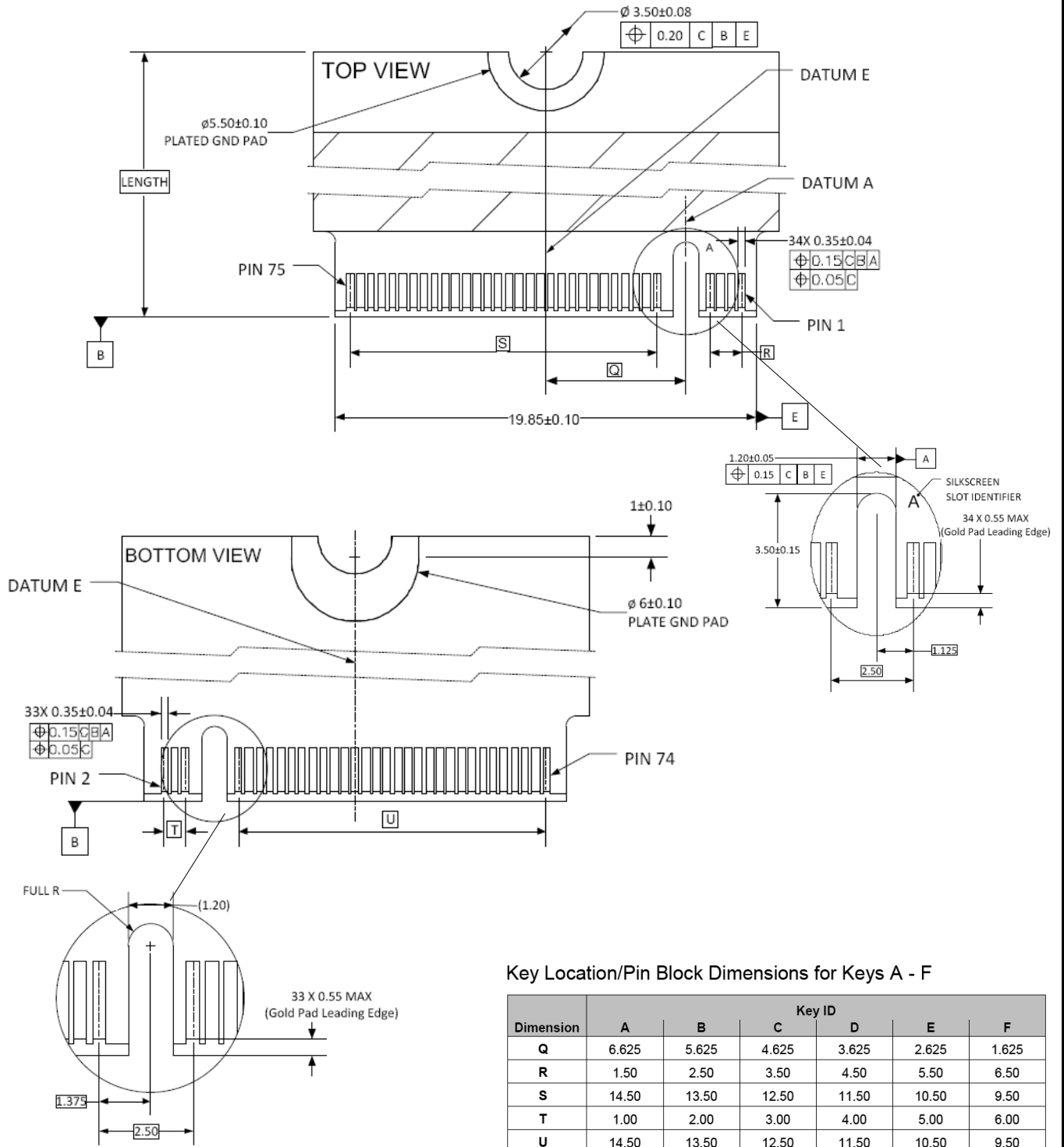

TITLE: **PCI EXPRESS M.2 CONNECTOR**

RELEASE DATE: 2019/03/22

REVISION: A

ECN No: ECN-1903263

PAGE: 13 OF 12

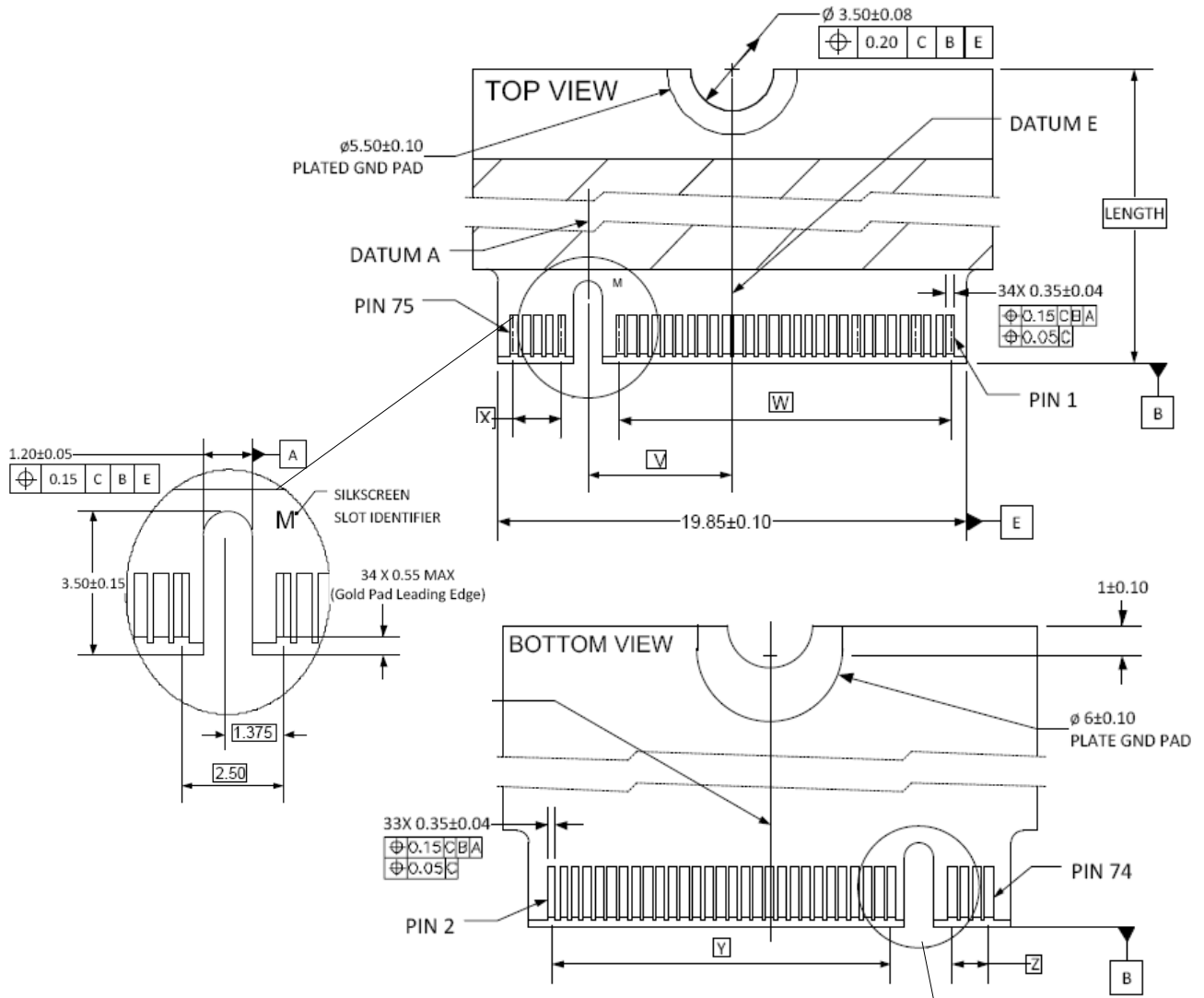

Key Location/Pin Block Dimensions for Keys G - M

Dimension	Key ID					
	G	H	J	K	L	M
V	1.125	2.125	3.125	4.125	5.125	6.125
W	9.00	10.00	11.00	12.00	13.00	14.00
X	7.00	6.00	5.00	4.00	3.00	2.00
Y	9.00	10.00	11.00	12.00	13.00	14.00
Z	6.50	5.50	4.50	3.50	2.50	1.50

